

UTC9106

LINEAR INTEGRATED CIRCUIT

TONE RINGER

DESCRIPTION

The UTC9106 is a bipolar integrated circuit designed for telephone bell replacement.

FUNCTIONS

- *Two oscillators
- *Output amplifier
- *Power supply control circuit

FEATURES

- *Designed for telephone bell replacement.
- *Low current drain.
- *Small size 'MINIDIP' package.
- *Adjustable 2-frequency tone.
- *Adjustable warbling rate.
- *Built-in hysteresis prevents false triggering and rotary dial 'CHIRPS'.
- *Extension tone ringer modules.
- *Alarms or other alerting devices.
- *Adjustable for reduced supply initiation current.

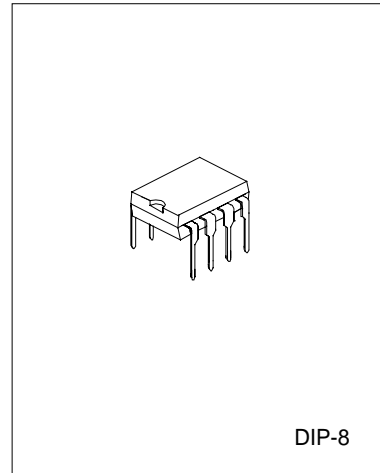

BLOCK DIAGRAM

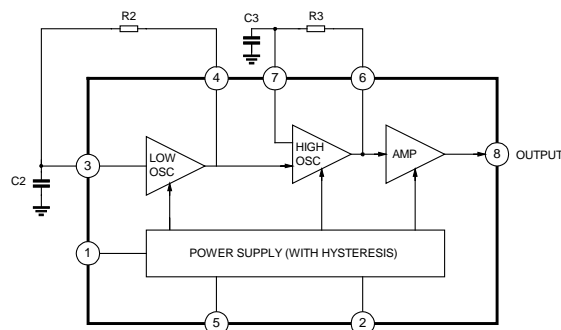

Note: R2, R3, C2 and C3 are parts externally mounted

ABSOLUTE MAXIMUM RATINGS (Ta=25°C)

Characteristic	Symbol	Value	Unit
Supply Voltage	Vcc	30	V
Power Dissipation	Pd	400	mW
Operating Temperature	Topr	-45 to 65	°C
Storage Temperature	Tstg	-65 to 150	°C

ELECTRICAL CHARACTERISTICS (Ta=25°C)

(All voltage referenced to GND unless otherwise specified)

Characteristic	Symbol	Test Condition	Min	Typ.	Max	Unit
Operating Supply Voltage	Vcc				29.0	V
Initiation Supply Voltage ¹	Vsi	See Fig.2	17	19	21	V
Initiation Supply Current ¹	I _{si}	6.8K-Pin 2 to GND	1.4	2.5	4.2	mA
Sustaining Voltage ²	V _{sus}	See Fig.2	9.7	11.0	12.0	V
Sustaining Current ²	I _{sus}	No Load Vcc=V _{sus} , See Fig.2	0.7	1.4	2.5	mA
Output Voltage High	V _{OH}	Vcc=21V, I ₈ =-15mA Pin6=6V, Pin7=GND	17.0	19.0	21.0	V
Output Voltage Low	V _{OL}	Vcc=21V, I ₈ =15mA Pin6=GND, Pin7=6V			1.6	V
I _{IN} (Pin3) I _{IN} (pin7)		Pin3=6V, Pin4=GND Pin7=6V, Pin6=GND	—	—	500	nA
High Frequency 1	F _{H1}	R3=191kΩ, C3=6800pF	461	512	563	Hz
High Frequency 2	F _{H2}	R3=191kΩ, C3=6800pF	576	640	704	Hz
Low Frequency	F _L	R2=165kΩ, C2=0.47μF	9.0	10	11.0	Hz

*NOTE (See electrical characteristics sheet)

1. Initiation supply voltage (V_{si}) is the supply voltage required to start the tone ringer oscillating.
2. Sustaining voltage (V_{sus}) is the supply voltage required to maintain oscillation.

APPLICATION NOTE

The application circuit illustrates the use of the UTC9106 device in typical telephone tone ringer application.

The AC ringer signal voltage appears across the TIP and RING inputs of the circuit and is attenuated by capacitor C1 and resistor R1.

C1 also provides isolation from DC voltage (48V) on the exchanged line.

After full wave rectification by the bridge diode, the waveform is filtered by capacitor C4 to provide a DC supply for the tone ringer chip.

As this voltage exceeds the initiation voltage (V_{si}), oscillation starts.

With the components shown, the output frequency chops between 512Hz (F_{H1}) and 640 Hz (F_{H2}) at a 10 Hz (F_L) rate.

The loudspeaker load is coupled through a 1300Ω to 8Ω transformer.

The output coupling capacitor C5 is required with transformer coupled loads.

When driving a piezo-ceramic transducer type load, the coupling C5 and transformer (1300Ω:8Ω) are not required.

However, a current limiting resistor is required.

The low frequency oscillator oscillates at a rate (F_L) controlled by an external resistor (R2) and capacitor (C2).

The frequency can be determined using the relation $F_L = 1/1.289 R_2 \cdot C_2$. The high frequency oscillates at a F_{H1}, F_{H2} controlled by an external resistor (R3) and capacitor (C3). The frequency can be determined using the relation $F_{H1} = 1/1.504 R_3 \cdot C_3$ and $F_{H2} = 1/1.203 R_3 \cdot C_3$.

Pin 2 of the UTC9106 allows connection of external resistor RSL, which is used to program the slope of the supply current vs supply voltage characteristics (see Fig.3), and hence the supply current up to the initiation voltage (V_{si}). This initiation voltage remains constant independent of RSL.

The supply current drawn prior to triggering varies inversely with RSL, decreasing for increasing value of resistance. Thus, increasing the value of RSL, will decrease the amount of AC ringing current required to trigger the device. As such, longer subscriber loops are possible since less voltage is dropped per unit length of loop wire due to the lower current level. RSL can also be used to compensated for smaller AC coupling capacitors (C5 on Fig.4) (higher impedance) to the line which can be used to alter the ringer equivalence number of a tone ringer circuit.

The graph in Fig.3 illustrates the variation of supply current with supply voltage of the UTC9106.

Three curves are drawn to show the variation of initiation current with RSL. Curve B (RSL=6.8kΩ) shows the I-V characteristic for UTC9106 tone ringer. Curve A is a plot with RSL<6.8kΩ and shows an increase in the current drawn up to the initiation voltage Vsi. The I-V characteristic after initiation remains unchanged. Curve C illustrates the effect of increasing RSL above 6.8kΩ initiation current decreases but again current after triggering is unchanged.

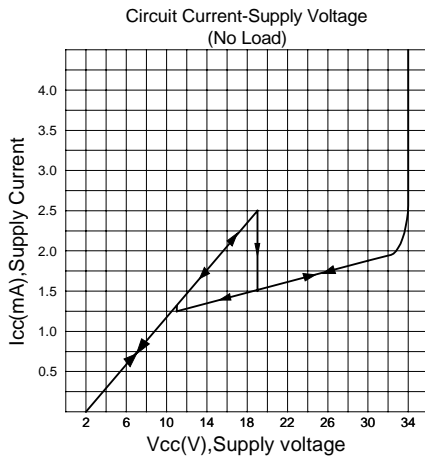

Fig.2

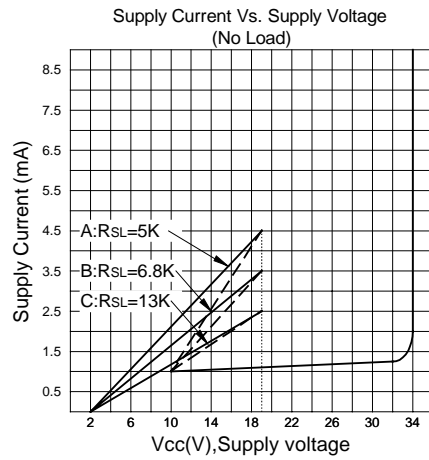

Fig. 3

APPLICATION CIRCUIT

